

2018+ Ford Fiesta ST MK8 Mud Flap Installation Instructions

View instructions and photos online www.rallyarmor.com

CARE AFTER INSTALLATION Once installed, the vehicle owner is responsible for the condition of the mud flaps and all costs associated with replacing damaged or lost parts. Warranty covers manufacturer defect on new, never installed parts.

⚠ Watch for blind spots when parking ⚠ Avoid contact with curbs, bumps and objects that can compress the flaps with excessive force. Be sure to check wheel clearances, especially on vehicles equipped with aftermarket wheels and suspensions.

QUESTION ON INSTALLATION? CONTACT US ONLINE www.rallyarmor.com/support

NEED TO PURCHASE REPLACEMENT PARTS? SEND RECEIPT OR PHOTO OF RALLY ARMOR LOGO ON FLAPS TO US www.rallyarmor.com/support

IMPORTANT NOTES

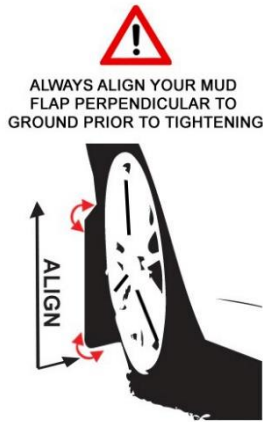

INSTALLATION KIT CONTENTS

QUANTITY	PART	ITEM ID
12	POLYGON CLIP	POLCLP
2	PLASTIC SPACER	.5SP
4	SMALL WASHER	SMWASH
16	WASHER	WASH
18	SHORT SCREW	1SS
2	MEDIUM SCREW	1.5SS
2	LONG SCREW	2SS
1	FOAM SPACER LEFT FRONT	SMF60-LF
1	FOAM SPACER RIGHT FRONT	SMF60-RF
2	INSERT	INS
8	INSERT 7	INS7
2	FRONT MOUNTING BRACKET 4	BRACKET 4
1	MOUNTING BRACKET LEFT REAR	BMF60-LR
1	MOUNTING BRACKET RIGHT REAR	BMF60-RR

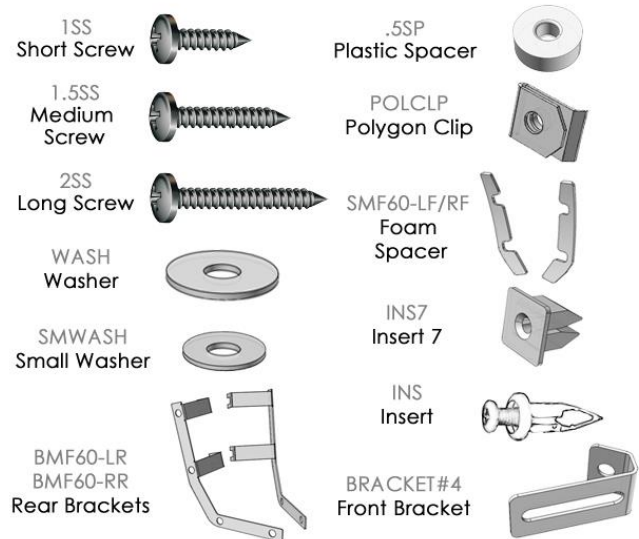

Recommended Tools Offset or ratcheting screw driver.

Important Tips Installation should be done on an even surface. Do not use power tools to tighten hardware. Hand tools only. Avoid overtightening.

RALLY ARMOR - A BIT ABOUT OUR STANDARD IN MUD FLAPS

Rally Armor mud flaps are fabricated from a high grade polyurethane plastic that is rigorously reviewed for quality and consistency. As with all manufacturing processes, controlled conditions and multiple QC checkpoints minimize major irregularities, however certain very minor surface layer marks appear periodically. These are visual variations that do not affect construction nor do they impede the performance of the flaps. Most matte away as the material ages naturally with continued exposure to the outdoors. Each flap is unique in appearance yet all are equally structurally sound.

2018+ Ford Fiesta ST MK8 Mud Flap Installation Instructions

FRONT MUD FLAP INSTALLATION

Bracket & Hardware 1 x Front Flap → 1 x BRACKET 4; 1 x INS; 1 x SMF60 LF/RF; 3 x 1SS; 1 x 1.5SS; 1 x 2SS; 4 x WASH; 1 x .5SP; 4 x POLCLP

To gain access to the inner wheel well area turn the steering wheel towards the side you are working on.

FIGURE A Uninstall original OEM liner fasteners 1, 2 & 3. Clean wheel well area then install POLYGON CLIP POLCLP over 1,2 & 3.

FIGURE B Remove OEM liner fastener 4. Prep INSERT INS by separating the plastic screw from the base. Install the INS base only into mounting point 4. Prep the FRONT MOUNTING BRACKET 4 with a POLYGON CLIP onto the slotted side, placing a LONG SCREW 2SS through the round hole. Position PLASTIC SPACER .5SP over INSERT then tighten the screw by placing a screwdriver through the long mounting slot as shown.

FIGURE C Reinstall wheel liner. Stick left/right side specific FOAM SPACER SMF60-LF/RF onto liner.



FIGURE D Place mud flap logo-side to the rear of the vehicle against mounting points on BRACKET 4 & liner. Pair WASHERS WASH & SHORT SCREWS 1SS to fasten mounts 1 & 2. Use a WASHER WASH & MEDIUM SCREW 1.5SS for point 3. Do not fully tighten.

FIGURE E For mount 4, use a SHORT SCREW 1SS & WASHER then install into the POLYGON CLIP affixed to BRACKET 4. Shift the POLYGON CLIP on the slot so it aligns with the flap mounting point.

FIGURE F Align outer edge of the flap by incrementally adjusting until the flap is perpendicular to even ground. Hand-tighten only until washers are seated.

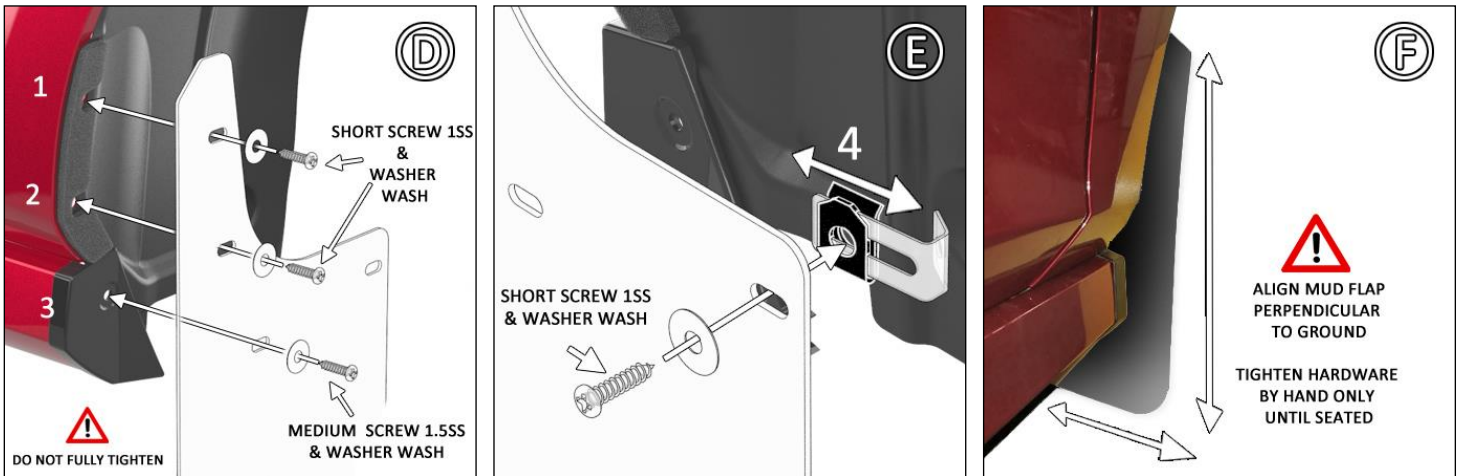

2018+ Ford Fiesta ST MK8 Mud Flap Installation Instructions

REAR MUD FLAP INSTALLATION

Bracket & Hardware 1 x Rear Flap → 1 x BMF60-LR/RR; 2 x POLCLP; 2 X SMWASH; 4 x WASH; 6 x 1SS; 4 x INS7

FIGURES G/H Remove original OEM fasteners 1 & 2 then install POLYGON CLIP POLCLP over 1 & 2. Reinstall fender liner.

FIGURE I Install REAR MOUNTING BRACKET BMF60-LR/RR onto points 1 & 2 using SHORT SCREWS 1SS & SMALL WASHERS SMWASH.

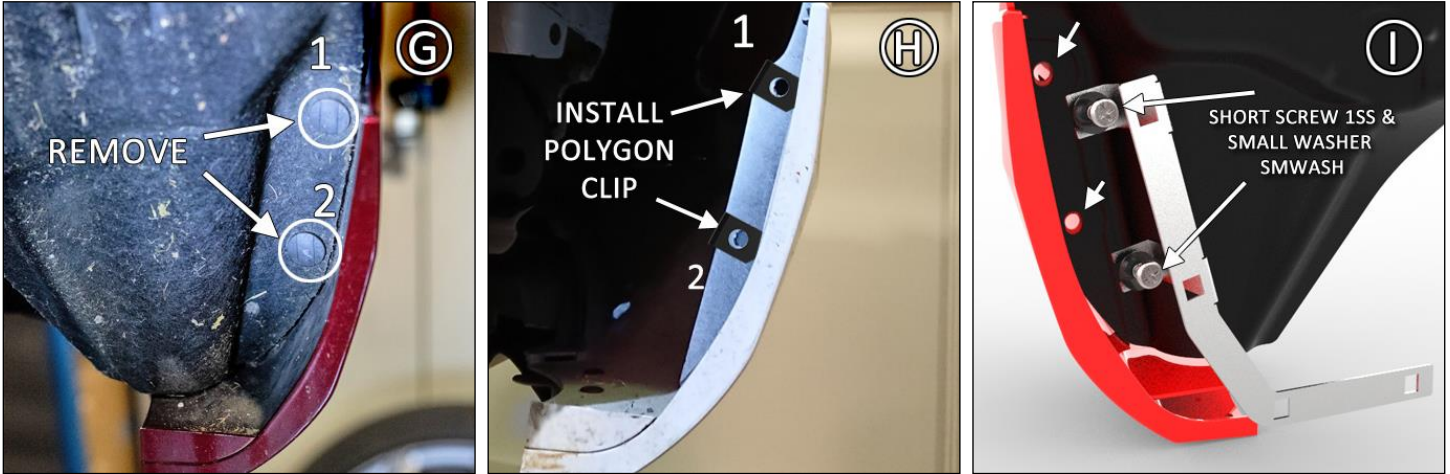

FIGURE J Refer to diagram J when positioning 4 x INSERT 7 into BRACKET square mounts - INSERT 7s in upper 2 tabs as shown and lower 2 tabs as shown. Push INSERT 7s in until fully seated.

FIGURE K Position logo-side of the flap to the rear of the vehicle. Line it up to Bracket mounting points then fasten using SHORT SCREWS 1SS & WASHERS WASH through all 4 x INSERT 7s. Hand tighten until flush. Avoid overtightening.

FIGURE L Make slight adjustments for even alignment before tightening all mounting screws. The lower section of the BRACKET can be bent towards the rear of the vehicle to ensure the flap nests flush against the liner.



IMF60



2018+ Ford Fiesta ST MK8 Mud Flap Installation Instructions

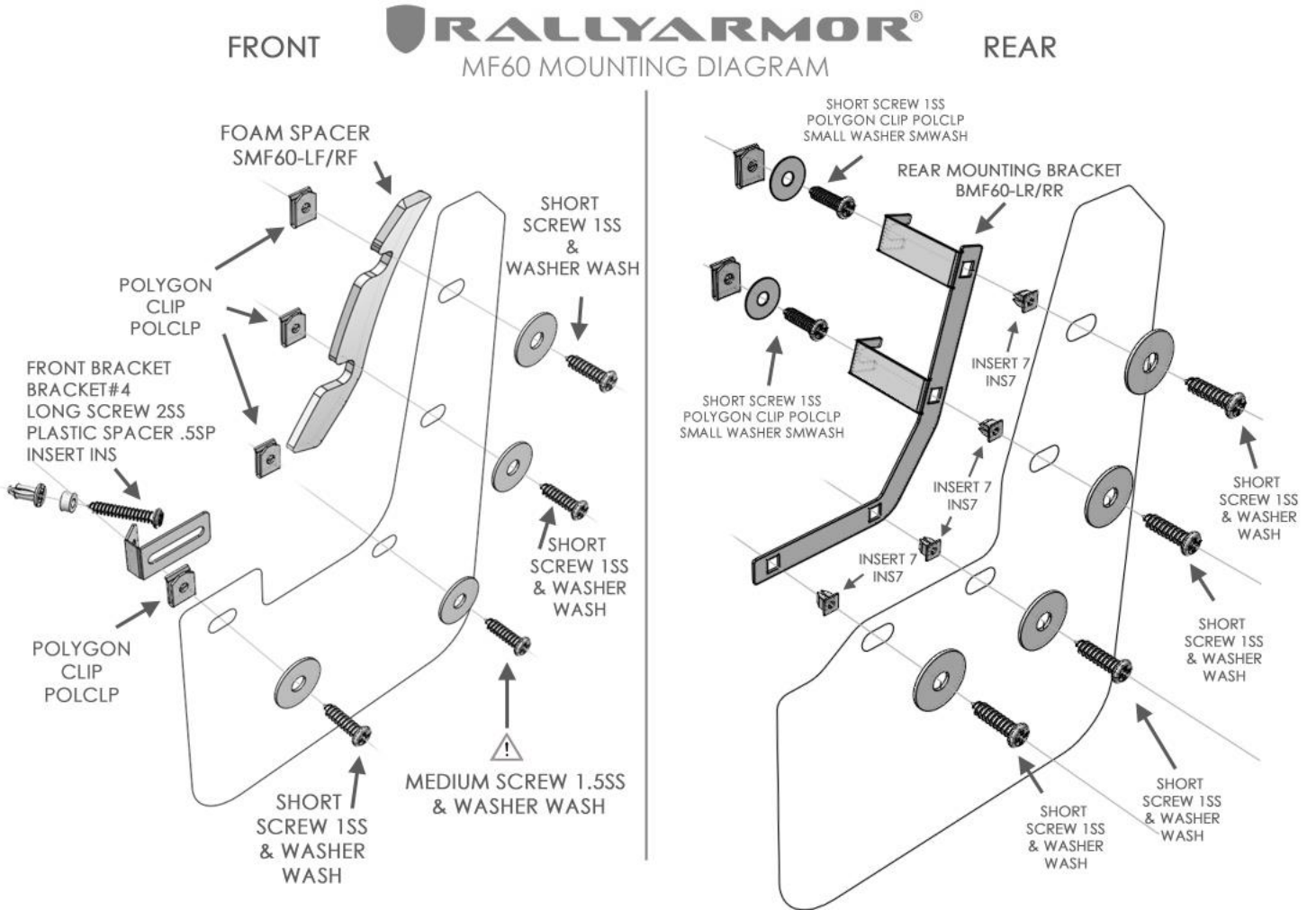

Content and images are copyright of Rally Armor® LLC